

iGEM

Template Models

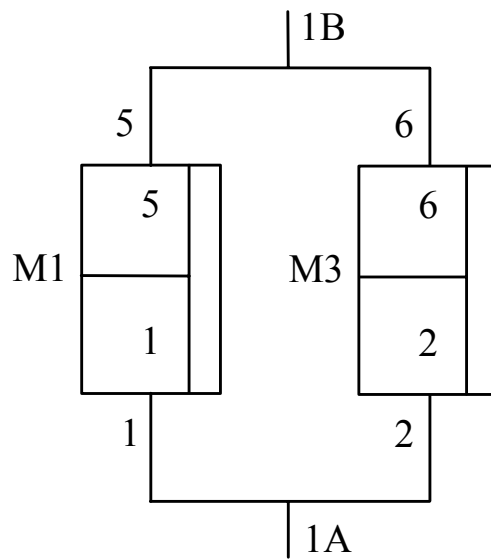



Product Liability

For the supplier's product liability to be valid, no alterations, additions or the like may be made to the equipment without the supplier's express permission.
Use only genuine parts



Produktansvar

För att en leverantörs produktansvar skall gälla får ändringar, kompletteringar och liknande ej göras i utrustningen utan leverantörens godkännande.
Originalreservdelar skall alltid användas.



Produkthaftung

Damit die Produkthaftung des Lieferanten ihre Gültigkeit behält, dürfen ohne ausdrückliche Genehmigung des Lieferanten keine Änderungen, Ergänzungen o. Ä. an der Ausrüstung vorgenommen werden.
Verwenden Sie nur Originalteile.



Ответственность поставщика

Для сохранения ответственности нельзя вводить в оборудование изменения, дополнения и т.п. без разрешения поставщика.
Пользуйтесь только оригинальными запасными частями, выпущенным изготовителем бензоколонки.

Caution

To prevent damage that might result in electric shock or fire, disconnect the main power prior to any work.

Varning

Gör pumpen/enheten strömlös innan Du gör ingrepp i den. I annat fall föreligger risk för skada.

Vorsicht

Um Beschädigungen zu vermeiden, die zu einem elektrischen Schlag oder Feuer führen können, unterbrechen Sie vor jeder Arbeit die Stromzufuhr.

Осторожно

Во избежание поражения электрическим током или пожара отключайте напряжение питания перед началом любых работ.

Warning

Never run a leaking pump!
Be careful with the environment and mind the skidding risk; take care of leaking fuel immediately.

Varning

Använd aldrig en läckande pump.
Tänk på miljön och halkrisken, sanera utläckt drivmedel snarast.

Warnung

Lassen Sie nie eine undichte Zapfsäule laufen! Seien Sie umweltbewusst und denken Sie an die Rutschgefahr; beseitigen Sie austretenden Kraftstoff umgehend.

Предупреждение

Не пользуйтесь колонкой при наличии утечки топлива!
Охраняйте окружающую среду, помните об опасности скольжения: в случае утечки топлива на дорожное покрытие возле колонки, примите меры немедленно.

The contents of this publication may not be copied either wholly or in part without the consent of Dresser Wayne AB.

Dresser Wayne AB reserves the right to change specifications contained in the text and illustrations without notice.

Innehållet i denna publikation får ej helt eller delvis kopieras utan medgivande från Dresser Wayne AB.

Dresser Wayne AB förbehåller sig rätten att utan särskilt meddelande ändra specifikationer givna i text och bild.

Der Inhalt dieses Handbuches darf ohne die Erlaubnis von Dresser Wayne weder ganz noch teilweise kopiert werden.

Dresser Wayne behält sich das Recht vor, textliche oder bildliche Inhalte ohne besondere Mitteilung zu ändern.

Не разрешается копировать полностью или частично содержание настоящей публикации без разрешения фирмы Dresser Wayne AB.

Dresser Wayne AB оставляет за собой право вносить изменения в спецификации, содержащиеся в тексте и иллюстрациях, без предварительного уведомления.

Contents

1	Revision History	5
1.1	Rev 1	5
1.2	Rev 2	5
1.3	Rev 3	5
1.4	Rev 4	5
1.5	Rev 5	5
2	General	6
2.1	General Name and Numbering	6
2.2	Definition of Global Star	6
2.3	Definition of Global Century	7
2.4	Definition of Single Equipped i-Meters	7
2.5	Configuration of Pumps in General	7
2.6	Configuration of 40-70 Diesel	8
2.7	Configuration of Single Sided Pumps (S)	8
3	Global Century Models	9
3.1	Pump Model 1	9
3.1.1	3/G2201 "Single 40" and "Single 70"	9
3.2	Pump Model 2	9
3.2.1	3/G2201/M "Single 40 SAT" and "Single 70 SAT"	9
3.3	Pump Model 3	9
3.3.1	3/G2211 "Single 100"	9
3.4	Pump Model 4	10
3.4.1	3/G2211/M "Single 100 SAT"	10
3.5	Pump Model 5	10
3.5.1	3/G2221 "Single 130"	10
3.6	Pump Model 6	10
3.6.1	3/G2221/M "Single 130 SAT"	10
3.7	Pump Model 7	11
3.7.1	3/G2203 "Duo 40/40", "Duo 40/70" and "Duo 70/70"	11
3.8	Pump Model 8	11
3.8.1	3/G2213/2 "Duo 100/70"	11
3.9	Pump Model 9	11
3.9.1	3/G2204/R "Duo SS 40/40", "Duo SS 40/70" and "Duo SS 70/70"	11
3.10	Pump Model 10	12
3.10.1	3/Gxxxx "Twin 40/40"	12
3.10.2	3/G2207 "Dual Twin 40"	12
3.11	Pump Model 11	12
3.11.1	3/G2222 and 3/G2227 "Twin 130"	12
3.12	Pump Model 12	13
3.12.1	3/G2222/2 and 3/G2227/2 "Twin 130/70"	13
3.13	Pump Model 13	13
3.13.1	3/G2209 "Quattro 40/40"	13
3.14	Pump Model 14	13
3.14.1	3/G2209/R "Quattro SS 40/40"	13
3.15	Pump Model 15	14
3.15.1	3/G3387 "Duo 100/100"	14
4	Global Star Models	15
4.1	Pump Model 50	15
4.1.1	C66-66 "Multi product - 12/6"	15
4.1.2	C55-55 "Multi product - 10/5"	15
4.1.3	C44-44	16
4.1.4	C33-33	16
4.1.5	C22-22	17
4.1.6	C11-11	17
4.2	Pump Model 51	18
4.2.1	C55-65 "10/5 - 2 x 130"	18
4.2.2	C44-54 "8/4 - 2 x 130"	18

4.2.3	C33-43 “6/3 – 2 x 130”	19
4.2.4	C22-32 “4/2 – 2 x 130”	19
4.2.5	C11-21 130	20
4.2.6	C11-31 SIM 130	20
4.3	Pump Model 52	21
4.3.1	C55-66 “12/5 – 2 x 130-40 (1+2)”	21
4.3.2	C44-55 “10/4 – 2 x 130-40 (1+2)”	21
4.3.3	C33-44 “8/3 – 2 x 130-40 (1+2)”	22
4.3.4	C22-33 “6/2 – 2 x 130-40 (1+2)”	22
4.3.5	C11-22 130/40	23
4.3.6	C11-32 130/40 SIM	23
4.4	Pump Model 53	24
4.4.1	C67-65 “10/7 (blending)”	24
4.4.2	C56-54 “8/6 (blending)”	24
4.4.3	C45-43 “6/5 (blending)”	25
4.4.4	C34-32	25
4.4.5	C23-21	26
4.5	Pump Model 54	27
4.5.1	C66-64 “8/6 (Product select button)”	27
4.5.2	C55-53 “6/5 (Product select button)”	27
4.5.3	C44-42	28
4.5.4	C33-31	28
4.6	Pump Model 55	29
4.6.1	C11-11 S 100	29
4.7	Pump Model 56	30
4.7.1	C11-21 130/40	30
4.8	Pump Model 57	31
4.8.1	C11-21 S 130 SAT	31
4.9	Pump Model 58	32
4.9.1	C11-21 130/40 SAT	32
4.10	Pump Model 59	33
4.10.1	Reserved	33
4.11	Pump Model 60	34
4.11.1	C11-32 130/40 SAT “4/2 2 x 130 SAT FS RS”	34
4.11.2	C11-21 130 SAT	34
4.11.3	C11-31 130 SAT “2/1 130 SAT FS RS SIM”	35
4.12	Pump Model 61	36
4.12.1	C45-44	36
4.12.2	C34-33	36
4.12.3	C23-22	37
4.13	Pump Model 62	38
4.13.1	C11-21 40/130	38
4.14	Pump Model 63	39
4.14.1	C44-44 40-90	39
4.14.2	C33-33 40-90	39
4.14.3	C22-22 40-90	40
4.14.4	C11-11 40-90	40
4.15	Pump Model 64	41
4.15.1	C22-2ASYM1 40/40	41
5	Notes	42
6	Market & Service	43

1 Revision History

1.1 Rev 1

By Anders Bergqvist 2003-09-26 Dresser Wayne Malmoe.

- based on PRS WM005057 Rev 3. With addition of models C11-32 130/40 SIM and C11-21 40/130.

1.2 Rev 2

By Anders Bergqvist 2003-12-09 Dresser Wayne Malmoe.

- Added template model 63, C44-44 40-90/40/40/40.

1.3 Rev 3

By Anders Bergqvist 2004-05-07 Dresser Wayne Malmoe.

- Added template model 15, Global Century 3/G3387 DUO 100/100.
- Added template model 64, Global Star C22-2ASYM1 40

1.4 Rev 4

By Anders Bergqvist 2004-11-08 Dresser Wayne Malmoe.

- Removed C11-21 S 130 from model 55 section. This model shall be programmed as template model 51.
- Modified template model 14, Global Century 3/G2209/R to have meter 1 be fed by motor 3 on second hydraulic.

1.5 Rev 5

By Anders Bergqvist 2005-04-28 Dresser Wayne Malmoe.

- Corrected template model 62, Global Star C11-21 40/130. iGEM SW also corrected in version 7.34.

2 General

2.1 General Name and Numbering

Side B = view of pulley

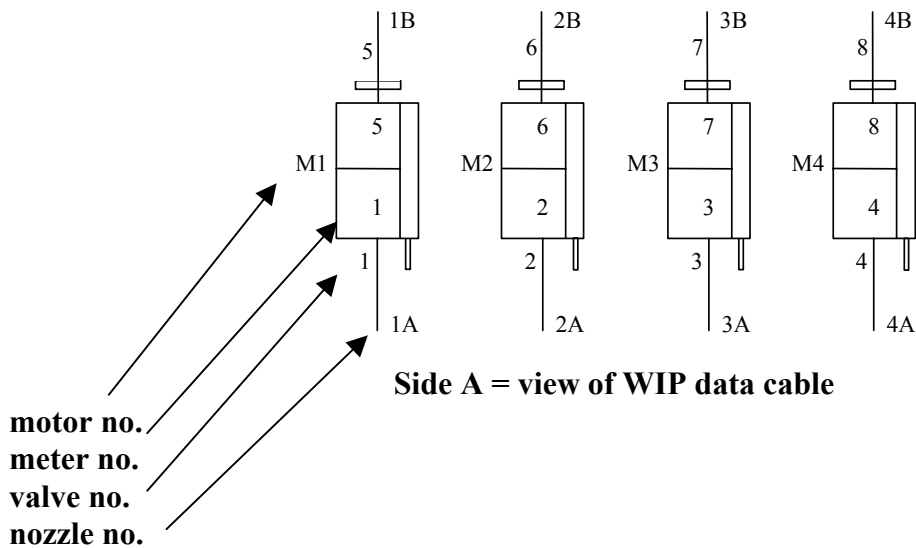

2.2 Definition of Global Star

Side B = view of pulley

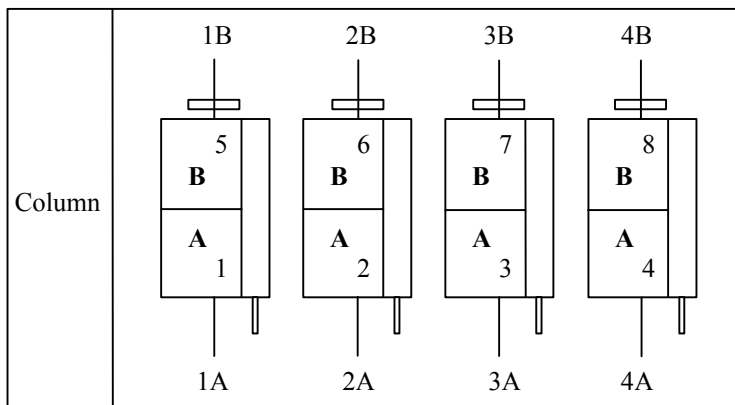

Side A = view of WIP cable

2.3 Definition of Global Century

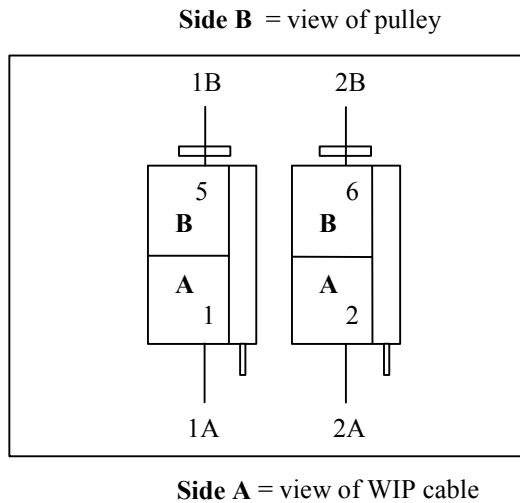

2.4 Definition of Single Equipped i-Meters

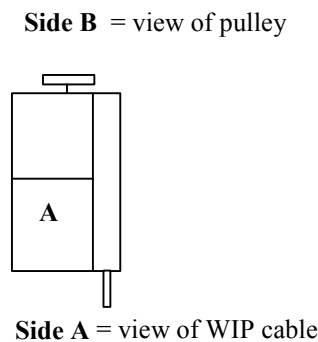

2.5 Configuration of Pumps in General

Perform the following steps using the iGEM programming manual [1]:

1. Select model in F37.00 according to this document.
2. Configure number of logical nozzles (F37.01).
3. If pump is equipped with other valve type than ASCO proportional set F37.03.
4. If special unit price display configuration is required set F37.04 and F37.05.
5. Set Country code in F38.
6. Set other parameters such as Filling mode, VAP, Preset, other flowrates e t c.

2.6 Configuration of 40-70 Diesel

To set up a 40-70 diesel nozzle do one of the following:

- a) Setup TOGGLE button in F10.5N and F11.5N for the logical diesel nozzle OR
- b) Setup HI button in F10.6N and F11.6N and LOW button in F10.7N and F11.7N for the logical diesel nozzle.

2.7 Configuration of Single Sided Pumps (S)

Set F37.02=1 (no of sides in pump=1). Single sided with side-B is basically a side-A pump with (side-A) nozzles and display placed placed/mounted on B-side of pump.

3 Global Century Models

3.1 Pump Model 1

3.1.1 3/G2201 "Single 40" and "Single 70"

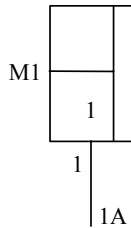

F37.00 = 1

Set flowrate in F29.21 (default = 50)

3.2 Pump Model 2

3.2.1 3/G2201/M "Single 40 SAT" and "Single 70 SAT"

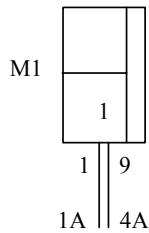

F37.00 = 2

Set flowrate in F29.2x (default = 50)

3.3 Pump Model 3

3.3.1 3/G2211 "Single 100"

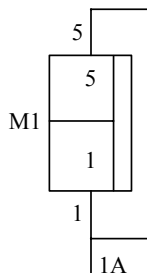

F37.00 = 3

3.4 Pump Model 4

3.4.1 3/G2211/M “Single 100 SAT”

F37.00 = 4

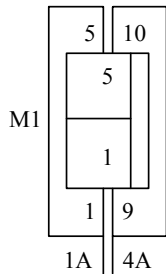

3.5 Pump Model 5

3.5.1 3/G2221 “Single 130”

F37.00 = 5

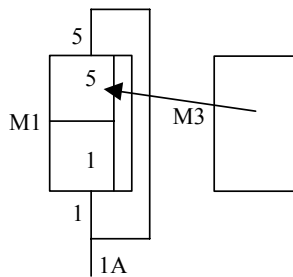

3.6 Pump Model 6

3.6.1 3/G2221/M “Single 130 SAT”

F37.00 = 6

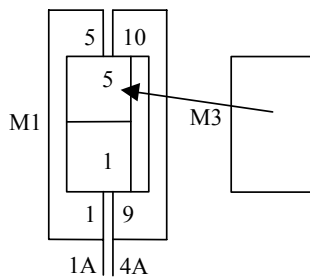

3.7 Pump Model 7

3.7.1 3/G2203 “Duo 40/40”, “Duo 40/70” and “Duo 70/70”

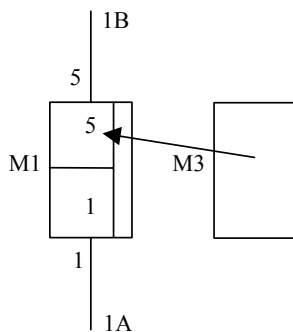

F37.00 = 7

Set flowrate in F29.2x and F30.2x (default = 50)

3.8 Pump Model 8

3.8.1 3/G2213/2 “Duo 100/70”

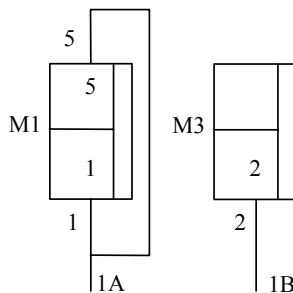

F37.00 = 8

Also used for “DUO SS 100/70”

3.9 Pump Model 9

3.9.1 3/G2204/R “Duo SS 40/40”, “Duo SS 40/70” and “Duo SS 70/70”

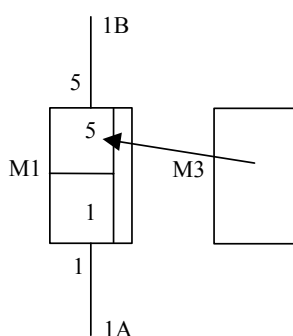

F37.00 = 9

Set flowrate in F29.2x and F30.2x (default = 50)

3.10 Pump Model 10

3.10.1 3/Gxxxx “Twin 40/40”

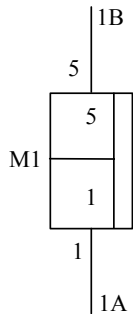

TWIN 40/40

F37.00 = 10

Set flowrate in F29.2x (default = 50)

3.10.2 3/G2207 “Dual Twin 40”

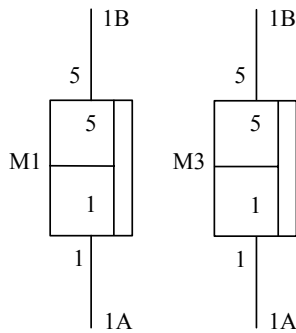

DUAL TWIN 40/40

F37.00 = 10

Same as TWIN 40/40 but equipped with 2 iGEM boards

3.11 Pump Model 11

3.11.1 3/G2222 and 3/G2227 “Twin 130”

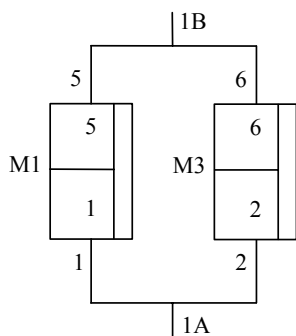

F37.00 = 11

3.12 Pump Model 12

3.12.1 3/G2222/2 and 3/G2227/2 “Twin 130/70”

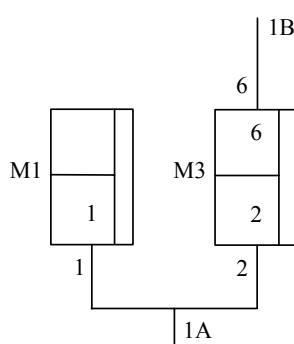

F37.00 = 12

Set flowrate in F30.2x to select 70 liter/min (default = 50)

3.13 Pump Model 13

3.13.1 3/G2209 “Quattro 40/40”

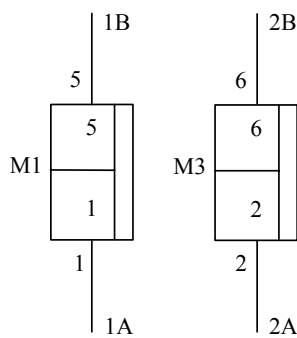

F37.00 = 13

Set flowrate in F29.2x (default = 50)

3.14 Pump Model 14

3.14.1 3/G2209/R “Quattro SS 40/40”

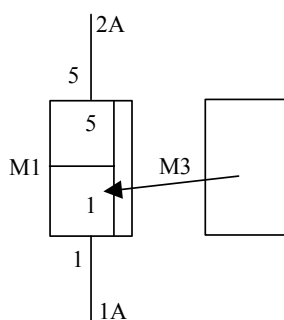

F37.00 = 14

Set flowrate in F29.2x (default = 50)

3.15 Pump Model 15

3.15.1 3/G3387 "Duo 100/100"

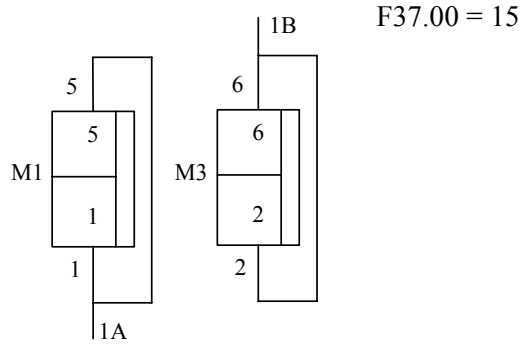

4 Global Star Models

4.1 Pump Model 50

4.1.1 C66-66 “Multi product - 12/6”

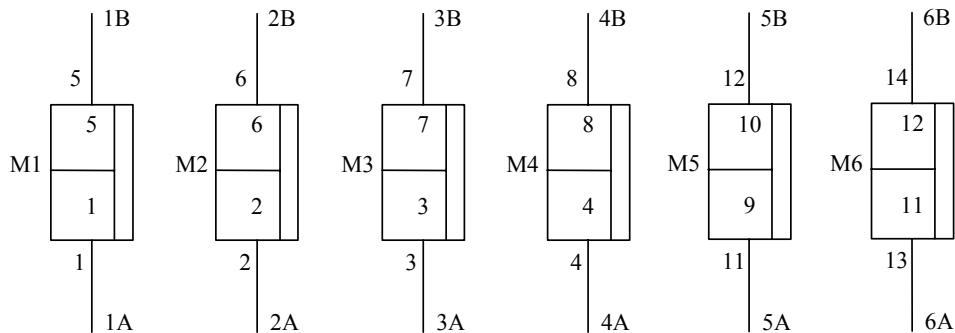

Set-up instruction:

F37.00	= 50 (Pump model)
F37.01	= 6 (Max. logical nozzle)
F37.03	= x (Valve type)
F38.00	= x (Country Code)
F01.00	= x (Filling mode)
F05/06	= x (Side A/B fuelling point)
F10.3N/11.3N	= x (Vapour recovery side A/B)
F26.00	= 0 (for pumps without VAP)
F20.00	= x (Protocol type)

Set other parameters according pump design (e.g. 40/80 l/min, preset, red/green lamp etc.)

4.1.2 C55-55 “Multi product - 10/5”

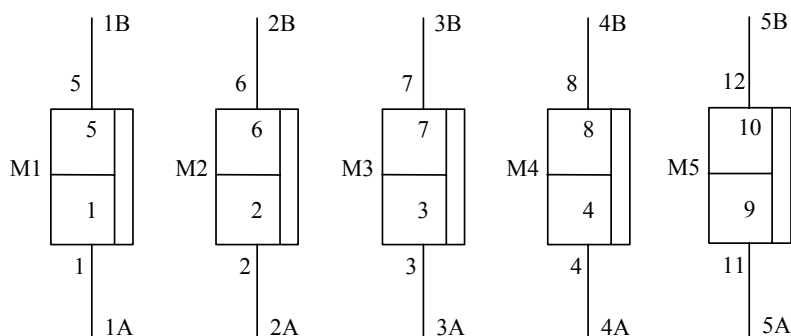

Set-up instruction:

F37.00	= 50 (Pump model)
F37.01	= 5 (Max. logical nozzle)
F37.03	= x (Valve type)
F38.00	= x (Country Code)
F01.00	= x (Filling mode)
F05/06	= x (Side A/B fuelling point)
F10.3N/11.3N	= x (Vapour recovery side A/B)
F26.00	= 0 (for pumps without VAP)
F20.00	= x (Protocol type)

Set other parameters according pump design (e.g. 40/80 l/min, preset, red/green lamp etc.)

4.1.3 C44-44

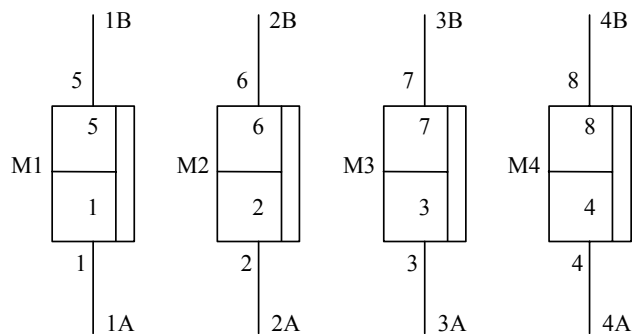

Set-up instruction:

F37.00	= 50 (Pump model)
F37.03	= x (Valve type)
F38.00	= x (Country Code)
F01.00	= x (Filling mode)
F05/06	= x (Side A/B fuelling point)
F10.3N/11.3N	= x (Vapour recovery side A/B)
F26.00	= 0 (for pumps without VAP)
F20.00	= x (Protocol type)

Set other parameters according pump design (e.g. 40/80 l/min, preset, red/green lamp etc.)

4.1.4 C33-33

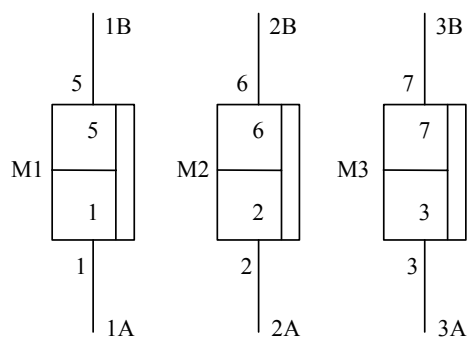

Set-up instruction:

F37.00	= 50 (Pump model)
F37.01	= 3 (Max. logical nozzle)
F37.03	= x (Valve type)
F38.00	= x (Country Code)
F01.00	= x (Filling mode)
F05/06	= x (Side A/B fuelling point)
F10.3N/11.3N	= x (Vapour recovery side A/B)
F26.00	= 0 (for pumps without VAP)
F20.00	= x (Protocol type)

Set other parameters according pump design (e.g. 40/80 l/min, preset, red/green lamp etc.)

4.1.5 C22-22

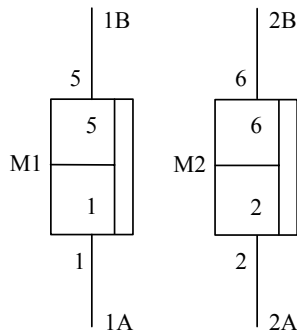

Set-up instruction:

F37.00	= 50 (Pump model)
F37.01	= 2 (Max. logical nozzle)
F37.03	= x (Valve type)
F38.00	= x (Country Code)
F01.00	= x (Filling mode)
F05/06	= x (Side A/B fuelling point)
F10.3N/11.3N	= x (Vapour recovery side A/B)
F26.00	= 0 (for pumps without VAP)
F20.00	= x (Protocol type)

Set other parameters according pump design (e.g. 40/80 l/min, preset, red/green lamp etc.)

4.1.6 C11-11

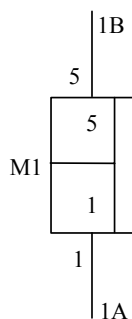

Set-up instruction:

F37.00	= 50 (Pump model)
F37.01	= 1 (Max. logical nozzle)
F37.03	= x (Valve type)
F38.00	= x (Country Code)
F01.00	= x (Filling mode)
F05/06	= x (Side A/B fuelling point)
F10.3N/11.3N	= x (Vapour recovery side A/B)
F26.00	= 0 (for pumps without VAP)
F20.00	= x (Protocol type)

Set other parameters according pump design (e.g. 40/80 l/min, preset, red/green lamp etc.)

4.2 Pump Model 51

4.2.1 C55-65 "10/5 – 2 x 130"

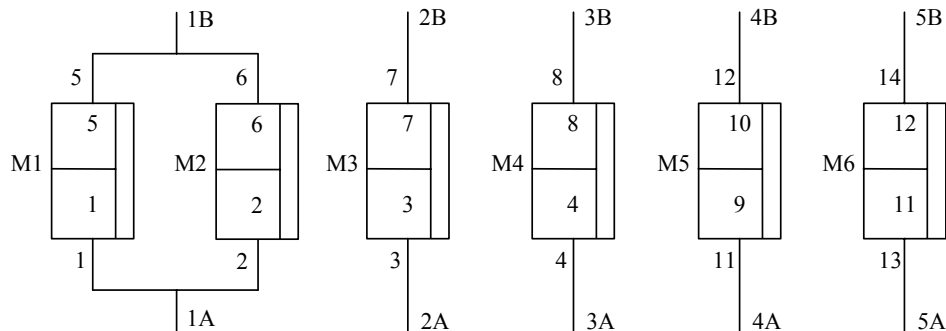

Set-up instruction:

F37.00	= 51 (Pump model)
F37.01	= 5 (Max. logical nozzle)
F37.03	= x (Valve type)
F38.00	= x (Country Code)
F01.00	= x (Filling mode)
F05/06	= x (Side A/B fuelling point)
F10.3N/11.3N	= x (Vapour recovery side A/B)
F26.00	= 0 (for pumps without VAP)
F20.00	= x (Protocol type)

Set other parameters according pump design (e.g. 40/80 l/min, preset, red/green lamp etc.)

4.2.2 C44-54 "8/4 – 2 x 130"

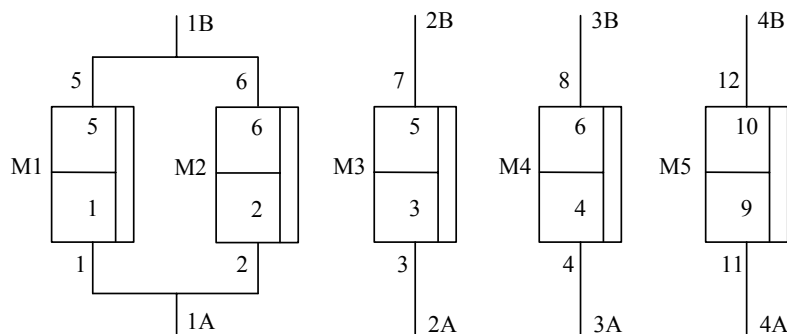

Set-up instruction:

F37.00	= 51 (Pump model)
F37.01	= 4 (Max. logical nozzle)
F37.03	= x (Valve type)
F38.00	= x (Country Code)
F01.00	= x (Filling mode)
F05/06	= x (Side A/B fuelling point)
F10.3N/11.3N	= x (Vapour recovery side A/B)
F26.00	= 0 (for pumps without VAP)
F20.00	= x (Protocol type)

Set other parameters according pump design (e.g. 40/80 l/min, preset, red/green lamp etc.)

4.2.3 C33-43 “6/3 – 2 x 130”

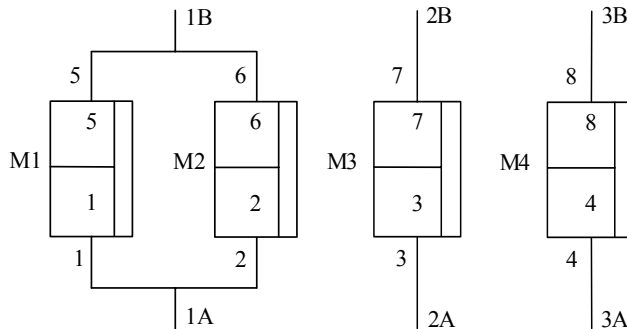

Set-up instruction:

F37.00	= 51 (Pump model)
F37.03	= x (Valve type)
F38.00	= x (Country Code)
F01.00	= x (Filling mode)
F05/06	= x (Side A/B fuelling point)
F10.3N/11.3N	= x (Vapour recovery side A/B)
F26.00	= 0 (for pumps without VAP)
F20.00	= x (Protocol type)

Set other parameters according pump design (e.g. 40/80 l/min, preset, red/green lamp etc.)

4.2.4 C22-32 “4/2 – 2 x 130”

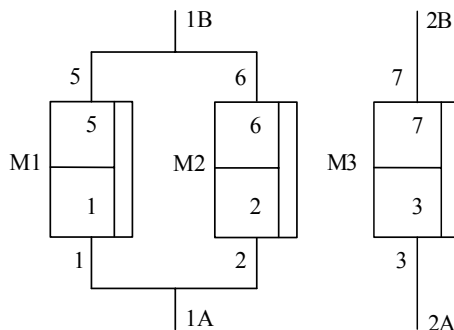

Set-up instruction:

F37.00	= 51 (Pump model)
F37.01	= 2 (Max. logical nozzle)
F37.03	= x (Valve type)
F38.00	= x (Country Code)
F01.00	= x (Filling mode)
F05/06	= x (Side A/B fuelling point)
F10.3N/11.3N	= x (Vapour recovery side A/B)
F26.00	= 0 (for pumps without VAP)
F20.00	= x (Protocol type)

Set other parameters according pump design (e.g. 40/80 l/min, preset, red/green lamp etc.)

4.2.5 C11-21 130

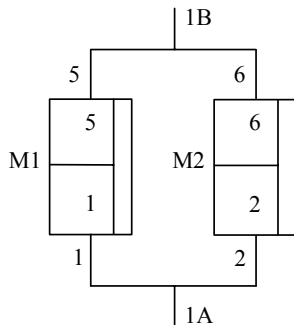

Set-up instruction:

F37.00	= 51 (Pump model)
F37.01	= 1 (Max. logical nozzle)
F37.03	= x (Valve type)
F38.00	= x (Country Code)
F01.00	= x (Filling mode)
F05/06	= x (Side A/B fuelling point)
F26.00	= 0 (for pumps without VAP)
F20.00	= x (Protocol type)

Set other parameters according pump design (e.g. 40/80 l/min, preset, red/green lamp etc.)

4.2.6 C11-31 SIM 130

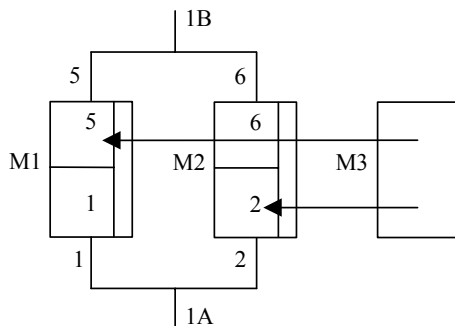

Set-up instruction:

F37.00	= 51 (Pump model)
F37.01	= 1 (Max. logical nozzle)
F37.03	= x (Valve type)
F38.00	= x (Country Code)
F01.00	= x (Filling mode)
F05/06	= x (Side A/B fuelling point)
F12.11	= 3 (Secondary pump assignment)
F13.01	= 3 (Primary pump assignment)
F26.00	= 0 (for pumps without VAP)
F20.00	= x (Protocol type)

Set other parameters according pump design (e.g. 40/80 l/min, preset, red/green lamp etc.)

4.3 Pump Model 52

4.3.1 C55-66 "12/5 – 2 x 130-40 (1+2)"

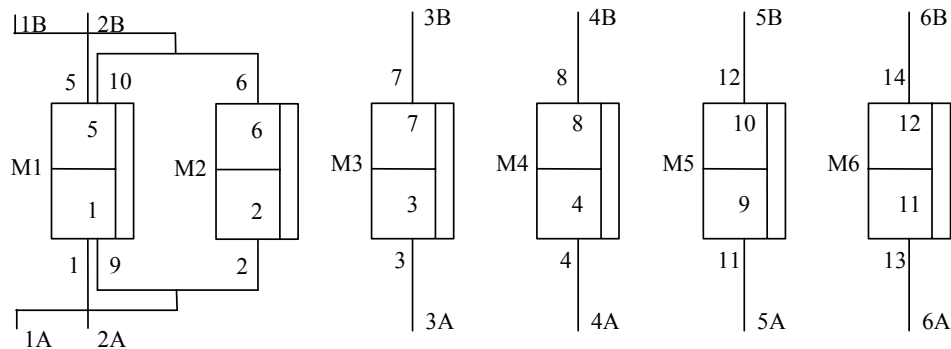

Set-up instruction:

F37.00	= 52 (Pump model)
F37.01	= 6 (Max. logical nozzle)
F37.03	= x (Valve type)
F38.00	= x (Country Code)
F01.00	= x (Filling mode)
F05/06	= x (Side A/B fuelling point)
F10.3N/11.3N	= x (Vapour recovery side A/B)
F26.00	= 0 (for pumps without VAP)
F20.00	= x (Protocol type)

Set other parameters according pump design (e.g. 40/80 l/min, preset, red/green lamp etc.)

4.3.2 C44-55 "10/4 – 2 x 130-40 (1+2)"

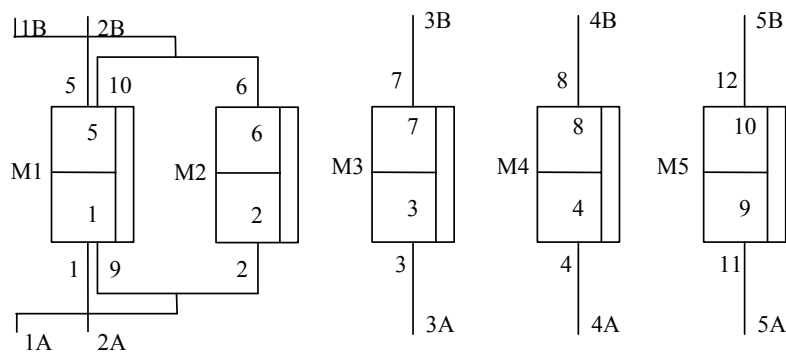

Set-up instruction:

F37.00	= 52 (Pump model)
F37.01	= 5 (Max. logical nozzle)
F37.03	= x (Valve type)
F38.00	= x (Country Code)
F01.00	= x (Filling mode)
F05/06	= x (Side A/B fuelling point)
F10.3N/11.3N	= x (Vapour recovery side A/B)
F26.00	= 0 (for pumps without VAP)
F20.00	= x (Protocol type)

Set other parameters according pump design (e.g. 40/80 l/min, preset, red/green lamp etc.)

4.3.3 C33-44 “8/3 – 2 x 130-40 (1+2)”

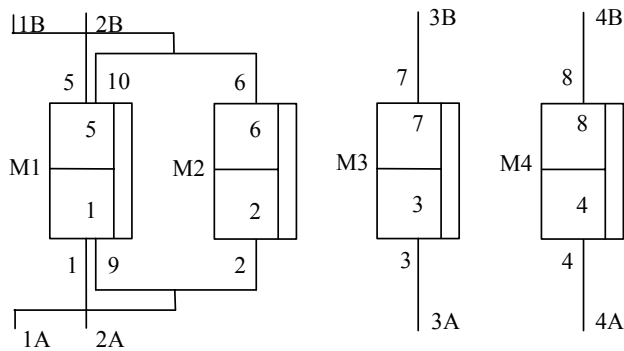

Set-up instruction:

F37.00	= 52 (Pump model)
F37.03	= x (Valve type)
F38.00	= x (Country Code)
F01.00	= x (Filling mode)
F05/06	= x (Side A/B fuelling point)
F10.3N/11.3N	= x (Vapour recovery side A/B)
F26.00	= 0 (for pumps without VAP)
F20.00	= x (Protocol type)

Set other parameters according pump design (e.g. 40/80 l/min, preset, red/green lamp etc.)

4.3.4 C22-33 “6/2 – 2 x 130-40 (1+2)”

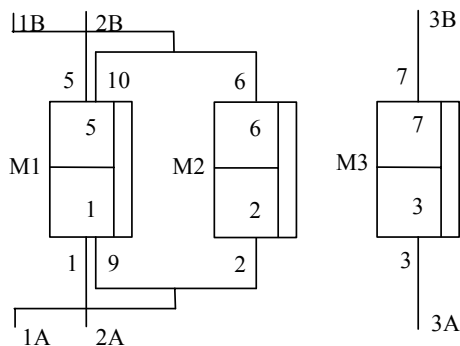

Set-up instruction:

F37.00	= 52 (Pump model)
F37.01	= 3 (Max. logical nozzle)
F37.03	= x (Valve type)
F38.00	= x (Country Code)
F01.00	= x (Filling mode)
F05/06	= x (Side A/B fuelling point)
F10.3N/11.3N	= x (Vapour recovery side A/B)
F26.00	= 0 (for pumps without VAP)
F20.00	= x (Protocol type)

Set other parameters according pump design (e.g. 40/80 l/min, preset, red/green lamp etc.)

4.3.5 C11-22 130/40

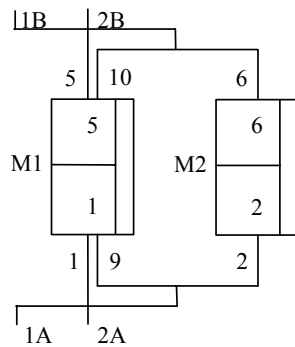

Set-up instruction:

F37.00	= 52 (Pump model)
F37.01	= 2 (Max. logical nozzle)
F37.03	= x (Valve type)
F38.00	= x (Country Code)
F01.00	= x (Filling mode)
F05/06	= x (Side A/B fuelling point)
F26.00	= 0 (for pumps without VAP)
F20.00	= x (Protocol type)

Set other parameters according pump design (e.g. 40/80 l/min, preset, red/green lamp etc.)

4.3.6 C11-32 130/40 SIM

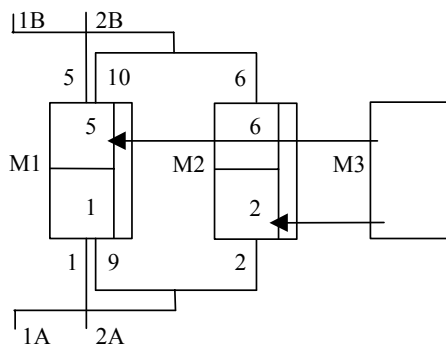

Set-up instruction:

F37.00	= 52 (Pump model)
F37.01	= 2 (Max. logical nozzle)
F37.03	= x (Valve type)
F38.00	= x (Country Code)
F01.00	= x (Filling mode)
F05/06	= x (Side A/B fuelling point)
F26.00	= 0 (for pumps without VAP)
F20.00	= x (Protocol type)
F12/F13..21	= 3 third motor for 130 lpm

4.4 Pump Model 53

4.4.1 C67-65 "10/7 (blending)"

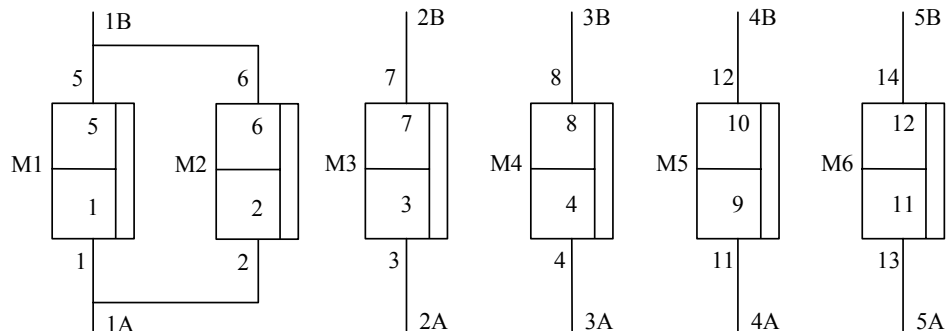

Set-up instruction:

F37.00	= 53 (Pump model)
F37.01	= 7 (Max. logical nozzle)
F38.00	= x (Country Code)
F01.00	= x (Filling mode)
F05/06	= x (Side A/B fuelling point)
F10.3N/11.3N	= x (Vapour recovery side A/B)
F26.00	= 0 (for pumps without VAP)
F20.00	= x (Protocol type)

Set other parameters according pump design (e.g. 40/80 l/min, preset, red/green lamp etc.)

4.4.2 C56-54 "8/6 (blending)"

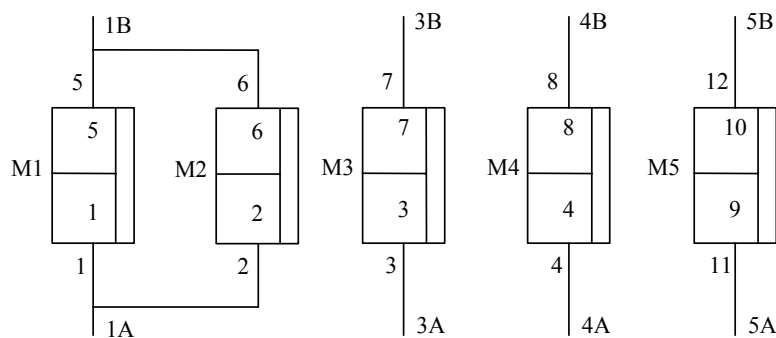

Set-up instruction:

F37.00	= 53 (Pump model)
F37.01	= 6 (Max. logical nozzle)
F38.00	= x (Country Code)
F01.00	= x (Filling mode)
F05/06	= x (Side A/B fuelling point)
F10.3N/11.3N	= x (Vapour recovery side A/B)
F26.00	= 0 (for pumps without VAP)
F20.00	= x (Protocol type)

Set other parameters according pump design (e.g. 40/80 l/min, preset, red/green lamp etc.)

4.4.3 C45-43 “6/5 (blending)”

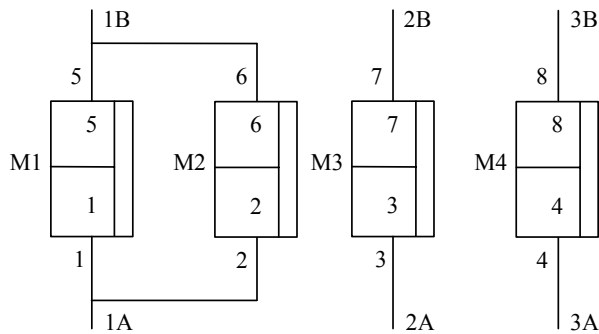

Set-up instruction:

F37.00	= 53 (Pump model)
F38.00	= x (Country Code)
F01.00	= x (Filling mode)
F05/06	= x (Side A/B fuelling point)
F10.3N/11.3N	= x (Vapour recovery side A/B)
F26.00	= 0 (for pumps without VAP)
F20.00	= x (Protocol type)

Set other parameters according pump design (e.g. 40/80 l/min, preset, red/green lamp etc.)

4.4.4 C34-32

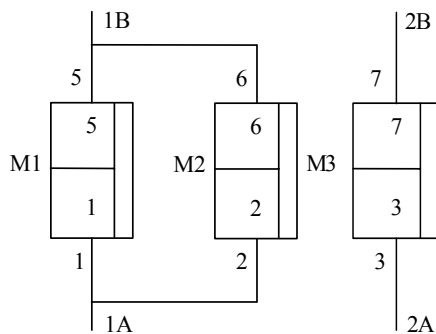

Set-up instruction:

F37.00	= 53 (Pump model)
F37.01	= 4 (Max. logical nozzle)
F38.00	= x (Country Code)
F01.00	= x (Filling mode)
F05/06	= x (Side A/B fuelling point)
F10.3N/11.3N	= x (Vapour recovery side A/B)
F26.00	= 0 (for pumps without VAP)
F20.00	= x (Protocol type)

Set other parameters according pump design (e.g. 40/80 l/min, preset, red/green lamp etc.)

NOTE!

The blend grade is located at logical nozzle no. 3. To run this pump as a C33-32, set the grade select button for logical nozzle 3 (F10.13 and F11.13) to a button that doesn't exist (e.g. F10.13=**24**). depending on Protocol and POS type, the price may still have to be set up in the system and sent to the pump.

4.4.5 C23-21

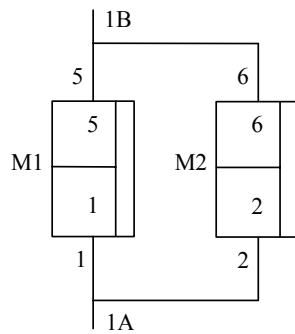

Set-up instruction:

- F37.00 = 53 (Pump model)
- F37.01 = 3 (Max. logical nozzle)
- F38.00 = x (Country Code)
- F01.00 = x (Filling mode)
- F05/06 = x (Side A/B fuelling point)
- F10.3N/11.3N = x (Vapour recovery side A/B)
- F26.00 = 0 (for pumps without VAP)
- F20.00 = x (Protocol type)

Set other parameters according pump design (e.g. 40/80 l/min, preset, red/green lamp etc.)

4.5 Pump Model 54

4.5.1 C66-64 “8/6 (Product select button)”

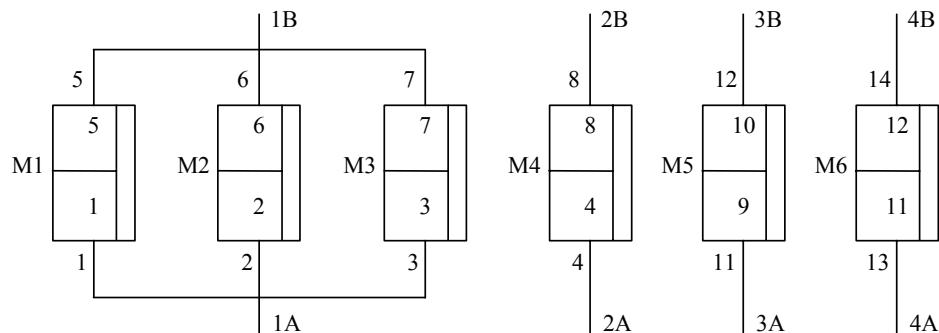

Set-up instruction:

F37.00	= 54 (Pump model)
F37.01	= 6 (Max. logical nozzle)
F37.03	= x (Valve type)
F38.00	= x (Country Code)
F01.00	= x (Filling mode)
F05/06	= x (Side A/B fuelling point)
F10.3N/11.3N	= x (Vapour recovery side A/B)
F26.00	= 0 (for pumps without VAP)
F20.00	= x (Protocol type)

Set other parameters according pump design (e.g. 40/80 l/min, preset, red/green lamp etc.)

4.5.2 C55-53 “6/5 (Product select button)”

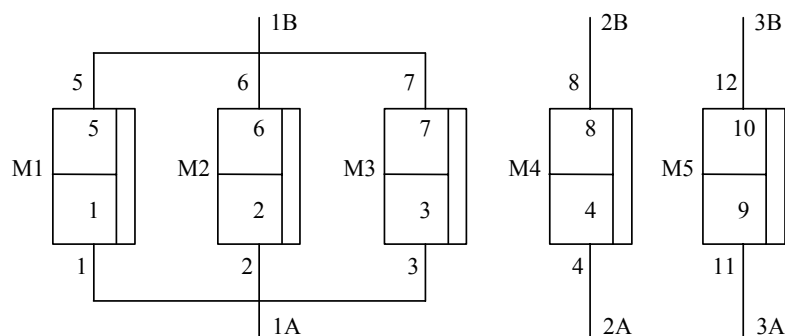

Set-up instruction:

F37.00	= 54 (Pump model)
F37.01	= 5 (Max. logical nozzle)
F37.03	= x (Valve type)
F38.00	= x (Country Code)
F01.00	= x (Filling mode)
F05/06	= x (Side A/B fuelling point)
F10.3N/11.3N	= x (Vapour recovery side A/B)
F26.00	= 0 (for pumps without VAP)
F20.00	= x (Protocol type)

Set other parameters according pump design (e.g. 40/80 l/min, preset, red/green lamp etc.)

4.5.3 C44-42

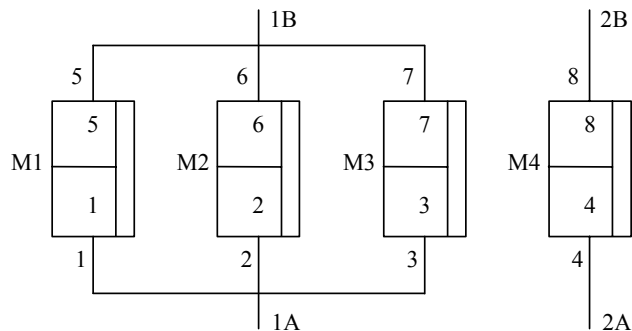

Set-up instruction:

F37.00	= 54 (Pump model)
F37.03	= x (Valve type)
F38.00	= x (Country Code)
F01.00	= x (Filling mode)
F05/06	= x (Side A/B fuelling point)
F10.3N/11.3N	= x (Vapour recovery side A/B)
F26.00	= 0 (for pumps without VAP)
F20.00	= x (Protocol type)

Set other parameters according pump design (e.g. 40/80 l/min, preset, red/green lamp etc.)

4.5.4 C33-31

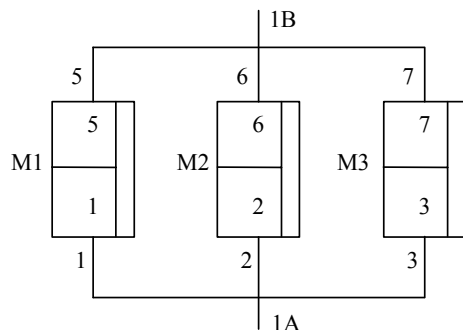

Set-up instruction:

F37.00	= 54 (Pump model)
F37.01	= 3 (Max. logical nozzle)
F37.03	= x (Valve type)
F38.00	= x (Country Code)
F01.00	= x (Filling mode)
F05/06	= x (Side A/B fuelling point)
F10.3N/11.3N	= x (Vapour recovery side A/B)
F26.00	= 0 (for pumps without VAP)
F20.00	= x (Protocol type)

Set other parameters according pump design (e.g. 40/80 l/min, preset, red/green lamp etc.)

4.6 Pump Model 55

4.6.1 C11-11 S 100

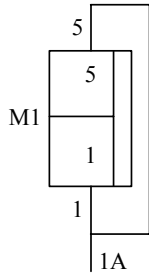

Set-up instruction:

F37.00	= 55 (Pump model)
F37.03	= x (Valve type)
F38.00	= x (Country Code)
F01.00	= x (Filling mode)
F05/06	= x (Side A/B fuelling point)
F26.00	= 0 (for pumps without VAP)
F20.00	= x (Protocol type)

Set other parameters according pump design (e.g. 40/80 l/min, preset, red/green lamp etc.)

4.7 Pump Model 56

4.7.1 C11-21 130/40

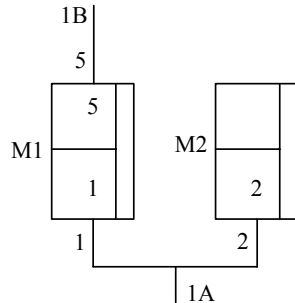

Set-up instruction:

F37.00 = 56 (Pump model)
F37.03 = x (Valve type)
F38.00 = x (Country Code)
F01.00 = x (Filling mode)
F05/06 = x (Side A/B fuelling point)
F26.00 = 0 (for pumps without VAP)
F20.00 = x (Protocol type)

Set other parameters according pump design (e.g. 40/80 l/min, preset, red/green lamp etc.)

4.8 Pump Model 57

4.8.1 C11-21 S 130 SAT

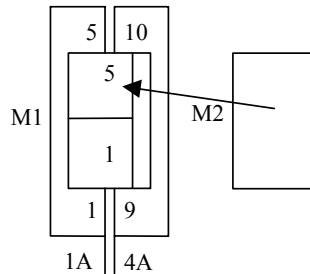

Set-up instruction:

- F37.00 = 57 (Pump model)
- F37.03 = x (Valve type)
- F38.00 = x (Country Code)
- F01.00 = x (Filling mode)
- F05/06 = x (Side A/B fuelling point)
- F26.00 = 0 (for pumps without VAP)
- F20.00 = x (Protocol type)

Set other parameters according pump design (e.g. 40/80 l/min, preset, red/green lamp etc.)

4.9 Pump Model 58

4.9.1 C11-21 130/40 SAT

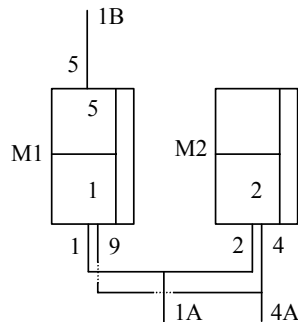

Set-up instruction:

F37.00	= 58 (Pump model)
F37.03	= x (Valve type)
F38.00	= x (Country Code)
F01.00	= x (Filling mode)
F05/06	= x (Side A/B fuelling point)
F26.00	= 0 (for pumps without VAP)
F20.00	= x (Protocol type)

Set other parameters according pump design (e.g. 40/80 l/min, preset, red/green lamp etc.)

4.10 Pump Model 59

4.10.1 Reserved

4.11 Pump Model 60

4.11.1 C11-32 130/40 SAT “4/2 2 x 130 SAT FS RS”

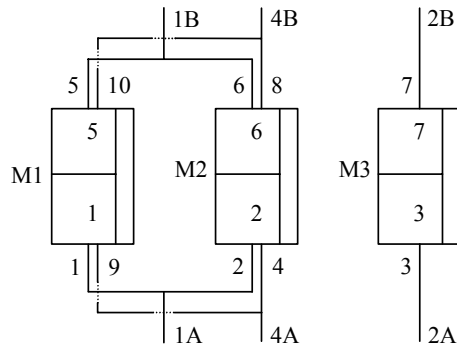

Set-up instruction:

F37.00	= 60 (Pump model)
F37.03	= x (Valve type)
F38.00	= x (Country Code)
F01.00	= x (Filling mode)
F05/06	= x (Side A/B fuelling point)
F26.00	= 0 (for pumps without VAP)
F20.00	= x (Protocol type)

Set other parameters according pump design (e.g. 40/80 l/min, preset, red/green lamp etc.)

4.11.2 C11-21 130 SAT

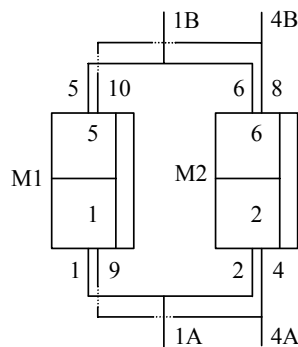

Set-up instruction:

F37.00	= 60 (Pump model)
F37.01	= 2 (Max. logical nozzle)
F37.03	= x (Valve type)
F38.00	= x (Pump model)
F01.00	= x (Filling mode)
F05/06	= x (Side A/B fuelling point)
F26.00	= 0 (for pumps without VAP)
F20.00	= x (Protocol type)

Set other parameters according pump design (e.g. 40/80 l/min, preset, red/green lamp etc.)

4.11.3 C11-31 130 SAT “2/1 130 SAT FS RS SIM”

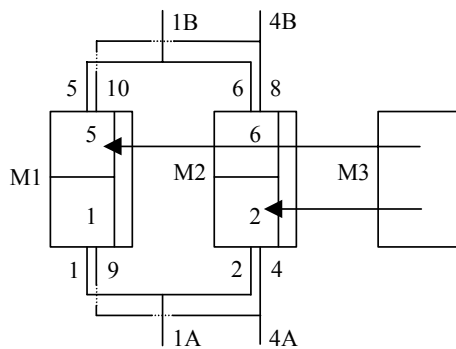

Set-up instruction:

F37.00	= 60 (Pump model)
F37.01	= 2 (Max. logical nozzle)
F37.03	= x (Valve type)
F38.00	= x (Country Code)
F01.00	= x (Filling mode)
F05/06	= x (Side A/B fuelling point)
F12.11	= 3 (Secondary pump assignment)
F12.12	= 3 (Secondary pump assignment)
F13.01	= 3 (Primary pump assignment)
F13.02	= 3 (Primary pump assignment)
F26.00	= 0 (for pumps without VAP)
F20.00	= x (Protocol type)

Set other parameters according pump design (e.g. 40/80 l/min, preset, red/green lamp etc.)

4.12 Pump Model 61

4.12.1 C45-44

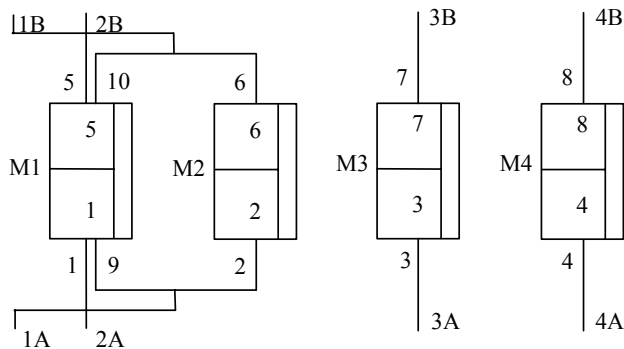

Set-up instruction:

F37.00	= 61 (Pump model)
F37.03	= x (Valve type)
F38.00	= x (Country Code)
F01.00	= x (Filling mode)
F05/06	= x (Side A/B fuelling point)
F10.3N/11.3N	= x (Vapour recovery side A/B)
F26.00	= 0 (for pumps without VAP)
F20.00	= x (Protocol type)

Set other parameters according pump design (e.g. 40/80 l/min, preset, red/green lamp etc.)

4.12.2 C34-33

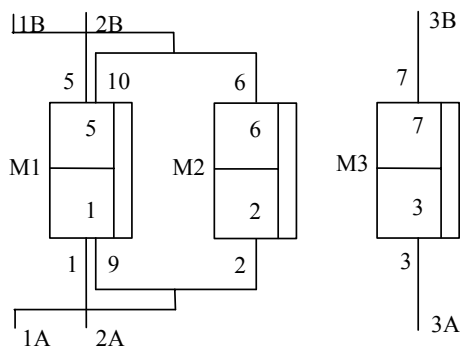

Set-up instruction:

F37.00	= 61 (Pump model)
F37.01	= 4 (Max. logical nozzle)
F37.03	= x (Valve type)
F38.00	= x (Country Code)
F01.00	= x (Filling mode)
F05/06	= x (Side A/B fuelling point)
F10.3N/11.3N	= x (Vapour recovery side A/B)
F26.00	= 0 (for pumps without VAP)
F20.00	= x (Protocol type)

Set other parameters according pump design (e.g. 40/80 l/min, preset, red/green lamp etc.)

4.12.3 C23-22

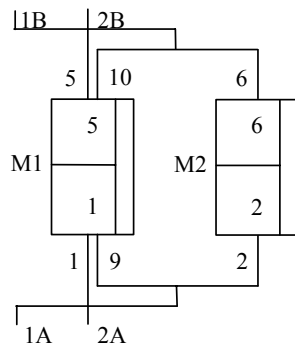

Set-up instruction:

F37.00	= 61 (Pump model)
F37.01	= 3 (Max. logical nozzle)
F37.03	= x (Valve type)
F38.00	= x (Country Code)
F01.00	= x (Filling mode)
F05/06	= x (Side A/B fuelling point)
F26.00	= 0 (for pumps without VAP)
F20.00	= x (Protocol type)

Set other parameters according pump design (e.g. 40/80 l/min, preset, red/green lamp etc.)

4.13 Pump Model 62

4.13.1 C11-21 40/130

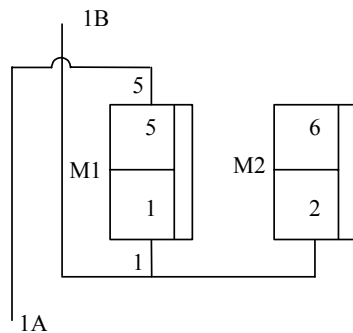

Set-up instruction:

F37.00	= 62 (Pump model)
F37.03	= x (Valve type)
F38.00	= x (Country Code)
F01.00	= x (Filling mode)
F05/06	= x (Side A/B fuelling point)
F26.00	= 0 (for pumps without VAP)
F20.00	= x (Protocol type)

Set other parameters according pump design (e.g. 40/80 l/min, preset, red/green lamp etc.)

4.14 Pump Model 63

4.14.1 C44-44 40-90

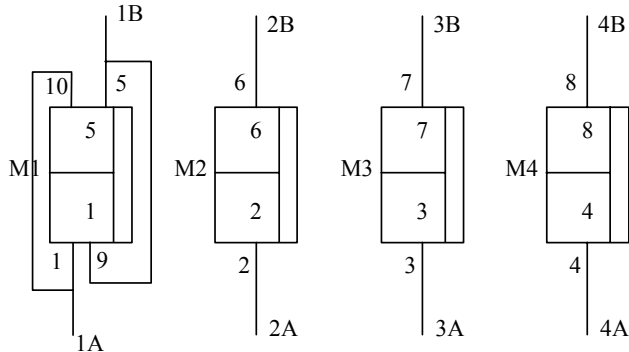

Set-up instruction:

F37.00	= 63 (Pump model)
F37.03	= x (Valve type)
F38.00	= x (Country Code)
F01.00	= x (Filling mode)
F05/06	= x (Side A/B fuelling point)
F10.3N/11.3N	= x (Vapour recovery side A/B)
F26.00	= 0 (for pumps without VAP)
F20.00	= x (Protocol type)

Set other parameters according pump design (e.g. remove Hi/Low buttons to get only 90 lpm, preset, red/green lamp etc.)

4.14.2 C33-33 40-90

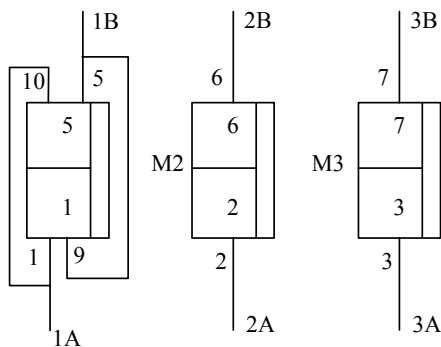

Set-up instruction:

F37.00	= 63 (Pump model)
F37.01	= 3 (Max. logical nozzle)
F37.03	= x (Valve type)
F38.00	= x (Country Code)
F01.00	= x (Filling mode)
F05/06	= x (Side A/B fuelling point)
F10.3N/11.3N	= x (Vapour recovery side A/B)
F26.00	= 0 (for pumps without VAP)
F20.00	= x (Protocol type)

Set other parameters according pump design (e.g. 40/80 l/min, preset, red/green lamp etc.)

4.14.3 C22-22 40-90

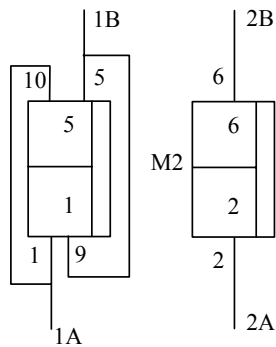

Set-up instruction:

F37.00	= 63 (Pump model)
F37.01	= 2 (Max. logical nozzle)
F37.03	= x (Valve type)
F38.00	= x (Country Code)
F01.00	= x (Filling mode)
F05/06	= x (Side A/B fuelling point)
F10.3N/11.3N	= x (Vapour recovery side A/B)
F26.00	= 0 (for pumps without VAP)
F20.00	= x (Protocol type)

Set other parameters according pump design (e.g. 40/80 l/min, preset, red/green lamp etc.)

4.14.4 C11-11 40-90

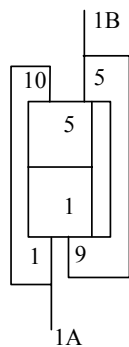

Set-up instruction:

F37.00	= 63 (Pump model)
F37.01	= 1 (Max. logical nozzle)
F37.03	= x (Valve type)
F38.00	= x (Country Code)
F01.00	= x (Filling mode)
F05/06	= x (Side A/B fuelling point)
F10.3N/11.3N	= x (Vapour recovery side A/B)
F26.00	= 0 (for pumps without VAP)
F20.00	= x (Protocol type)

Set other parameters according pump design (e.g. 40/80 l/min, preset, red/green lamp etc.)

4.15 Pump Model 64

4.15.1 C22-2ASYM1 40/40

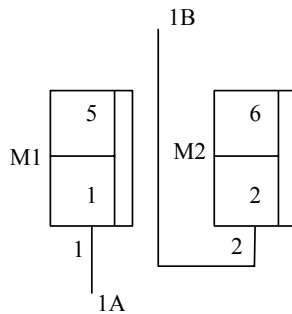

Set-up instruction:

F37.00	= 64 (Pump model)
F37.03	= x (Valve type)
F38.00	= x (Country Code)
F01.00	= x (Filling mode)
F05/06	= x (Side A/B fuelling point)
F26.00	= 0 (for pumps without VAP)
F20.00	= x (Protocol type)

Set other parameters according pump design (e.g. 40/80 l/min, preset, red/green lamp etc.)

6 Market & Service

Sweden

Dresser Wayne AB

Box 30049

SE-200 61 Malmö

Tel + 46 40-36 05 00

Fax + 46 40-15 03 81

www.wayne.se

E-mail: info@wayne.se

Felanmälan Sverige:

(Help desk)

Tel: 0771-420430

E-mail: service@wayne.se

Italy

**Dresser Wayne Pignone -
Deg Italia S.p.a.**

Via Giovanni Piantanida, 12
50127 FIRENZE (FI), Italy

Tel +39 055 3039 200

Fax +39 055 3039 007

UK

Dresser Wayne, DI UK Ltd

Butlerfield Industrial Estate,
Bonnyrigg, Midlothian,
Scotland. EH19 3JQ

Tel. +44 (0)1875 402141

Fax +44 (0)1875 400010

www.wayneuk.com

E-mail: Sales@bonx-wayne.com





More than a century of experience Über 100 Jahre Erfahrung Mer än 100 års erfarenhet Более, чем столетний опыт работы



Wayne Dresser develops, manufactures and markets complete operative systems for fuel handling at service stations. Everything from development and design to efficient production and assembly of components is pursued under one roof.

Wayne Dresser entwickelt, produziert und vermarktet komplette funktionierende Systeme für die Abgabe von Kraftstoffen an Tankstellen.. Von der Entwicklung über das Design bis zur Herstellung und Installation liefern wir alles aus einer Hand.

Wayne Dresser utvecklar, tillverkar och marknadsför kompletta operativa system för drivmedelshandling på servicestationer. Under ett och samma tak ryms allt från utveckling och konstruktion till rationell tillverkning och sammansättning av komponenter.

Wayne Dresser разработывает, производит и продает совершенные оперативные системы для торговли топлива на станциях обслуживания. Все начиная от разработок и конструкции до эффективного производства и сборки компонентов происходит в пределах одного предприятия.

The operations of Wayne Dresser comprise four interacting parts:

- Equipment such as petrol pumps, payment terminals, point-of-sale terminals and service station operative systems.
- Software for recording and for internal communication at the station, as well as between the station and the oil company, banks and credit institutes.
- Project design with overall responsibility to the customer.
- Field service, technical support and supply of spare parts.

Wayne Dresser makes it easier for the motorist to fill up and make his motoring purchases, while effectively meeting the needs of the service station owner for operating supervision and for conforming to the demands of the authorities on measuring accuracy, minimising pollution and ensuring safety.

Die Niederlassungen von Wayne Dresser umfassen vier ineinander greifende Bereiche:

- Ausrüstungen wie Zapfsäulen, Zahlterminals, Kassenterminals und Tankstellensysteme
- Software für Registrierung und Kommunikation auf der Tankstelle u. zwischen Station und Mineralölfirma sowie Banken und Kreditinstituten.
- Projektgestaltung mit umfassender Verantwortlichkeit dem Kunden gegenüber.
- Service, technische Unterstützung und Lieferung von Ersatzteilen.

Wayne Dresser erleichtert dem Fahrer die Betankung und damit verbundene Einkäufe, unterstützt gleichzeitig den Stationär bei der übersichtlichen Führung seines Betriebes unter Berücksichtigung der behördlichen Vorschriften hinsichtlich Messgenauigkeit, Umwelt- und Sicherheitsauflagen.

Verksamheten omfattar fyra samverkande delar:

- Utrustning som bensinpumpar, betalterminaler, butiksterminaler och stationsdatorer.
- Programvara för registrering och kommunikation internt på stationen samt mellan stationen och oljebolaget, banker och kreditinstitut.
- Projektering med totalansvar gentemot uppdragsgivaren.
- Service på fältet, teknisk support och reservdelsförsörjning.

Wayne Dresser gör det lättare för bilisten att tanka och handla. Samtidigt tillgodoses stationsägarens krav på en effektiv driftskontroll och myndighetskraven på mätnoggrannhet, miljövänlighet och driftssäkerhet.

Действия Wayne Dresser включают четыре взаимосвязанных направления:

- Оборудование, например, топливораздаточные колонки, платежные терминалы, терминалы точек продажи и системы управления АЗС.
- Программное обеспечение для регистрации и для внутренней связи на АЗС, а также между АЗС и нефтяной компанией, банками и институтами кредитов.
- Проектирование с полной ответственностью к клиенту.
- Обслуживание на местах, техническая поддержка и поставка запасных частей.

Wayne Dresser упрощает процесс заправки и приобретения покупок при эффективном согласовании потребностей владельца АЗС для оперативного управления и для соблюдения требований государственных и метрологических служб, а также уменьшения загрязнения окружающей среды и обеспечения безопасности.